



EM/M-E



The illustrations and details reported are indicative only. Lamborghini Calor reserves the right to introduce alterations and/or amendments as it deems fit and proper for the development of the product without the obligation of providing prior notice. | 2/03 - cod B036/UK - Mc Parker - Pn



Lamborghini Calor s.p.a.
Via Statale 342 - 44040 Dosso (Ferrara) - Italia
Tel. Italia 0532 / 359811 - Tel. Export 0532 / 359913
Fax Italia 0532 / 359952 - Fax Export 0532 / 359947
Internet: <http://www.lamborghinicalor.it>
E-mail: info@lamborghinicalor.it

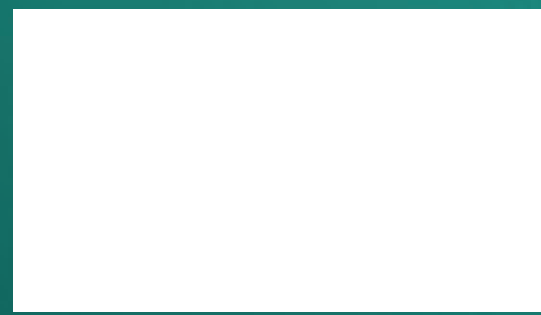

EM/M-E gas burners - 2 progressive stages

EM/M-E: innovative burners

The EM/M-E burners were born out of long experience accrued by Lamborghini in the gas combustion sector. EM/M-E have been manufactured with the very latest technology and some additional features are:

- High-powered fan that ensures a perfect burner operation even in the presence of high backpressure in the combustion chamber.
- Structure and precision of the mixing head providing high combustion efficiency with reduced CO and NOx emissions.

Maximum safety and reliability

The EM/M-E burners can operate with natural or liquid gas and conform to European directives. At the production stage particular attention was given to the safety aspect by equipping them with:

- Electronic control box
 - Flame control with ionisation electrode
 - Class A gas valves
 - Air pressure switch
 - Gas pressure switch
- EM/M-E burners are CE certified.

Design

Special study and attention has also been given to the look and dimension of these burners:

- The dimensions observe the connection requirements of the burner with the small boilers
- The shape and the colour of the casing were chosen because the appliance is designed to have a pleasing appearance and be adaptable to all types of boiler.

The casing also fulfils the important role of soundproofing the burner, making its operation extremely quiet.



Lamborghini
CALORECLIMA

Company certified UNI EN ISO 9001



The range

A wide range for the right choice

The EM/M-E range of burners comprises 4 models with reduced-delivery starting and 2 progressive stages operation, obtained by a class A progressive opening/closing gas valve synchronised with the electrical servo control (automatic air shutter).

They can operate on continuous modulation if equipped with modulation kit.

- **EM 26/M-E**
Max. heat output: 250 kW
- **EM 40/M-E**
Max. heat output: 390 kW
- **EM 50/M-E**
Max. heat output: 582 kW
- **EM 70/M-E**
Max. heat output: 740 kW

EM 26/M-E



EM 40/M-E



EM 50/M-E
EM 70/M-E



Packaging and weight

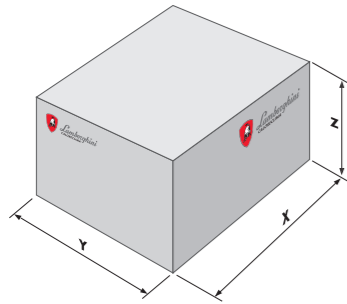

Model X	Dimensions Y			Gross weight Z
	cm.	cm.	cm.	kg.
EM 26/M-E	84	45	51	31
EM 40/M-E	96	50	54	44
EM 50/M-E	120	52	70	44
EM 70/M-E	120	52	70	80

Installation and maintenance

Universal flange and easy electrical connection for rapid installation

EM/M-E burners are equipped with a universally-bored sliding flange that facilitates installation of the burner onto any boiler type. These flanges are independent of the burner body and so allow for rapid maintenance. Electrical connection proves to be a simple task as a 7-pin plug is supplied for quick insertion into the burner socket, thus avoiding mistakes in connection.

Kit on request

The EM/M-E series burners may be made complete with appropriate devices or instrumentation supplied in assembly kit form in accordance with the regulations existent in various countries.

Seal control kit

A device for preventing gas leaks.

Assembly accessory kit

For an increasingly efficient gas train.

Pressure modulation kit

Controls vapour pressure in installations with heat generators operating with oil or gas.

Temperature modulation kit

Controls boiler temperature in installations with heat generators operating with oil or gas.

Easy maintenance

For convenient maintenance the main electrical components are connected by easy-to-fit plugs and each component has a different type. Removal of the casing gives one access to the main burner components.

The component plate can be separated from the burner body and hung up in the servicing position. It is possible therefore to carry out maintenance operations without having to separate the burner from the boiler.

For EM 50/M-E and EM 70/M-E models the combustion head and ignition and control electrodes are also made accessible. For EM 26/M-E and EM 40/M-E models the hinge flange, located between the burner body and the conveyor pipe, allows inspection of the combustion head and electrodes.



Inspection of combustion head

Construction features

Air adjustment

On the models of the EM/M-E series the amount of air entering the burner is adjusted by the air shutter actuated by an electric servo control. Air adjustment for the first and second stage is carried out on the appropriate servo control cams. There is a brief delay for the second stage starting with regard to the initial air opening. This delay is adjustable with a suitable cam on the servo control, for adjustment to the type of installation.

Combustion head adjustment

This may be carried out with the burner on and varies the position of the combustion head in regard to the trunk/tapered section of the draught tube to obtain an optimum combustion.

The operation is carried out by adjusting 2 knobs located on the side of the conveyor pipe.

Air shutter with automatic closing

This characteristic slows down the cooling process of the boiler when the burner is turned off, limiting the thermal shock as a result. An effective energy saving is obtained from this feature.



Servo control for combustion air adjustment



Combustion head adjustment



Dimensions

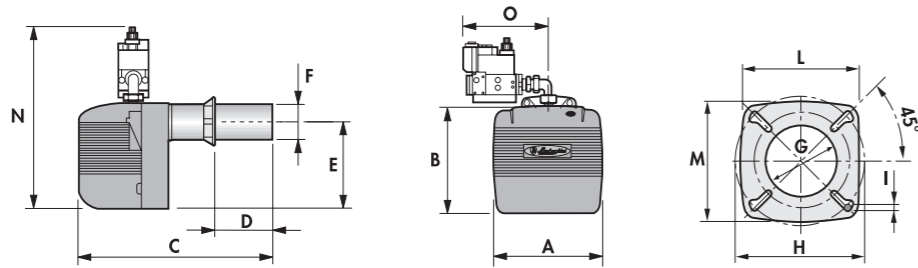

EM 26/M-E burner

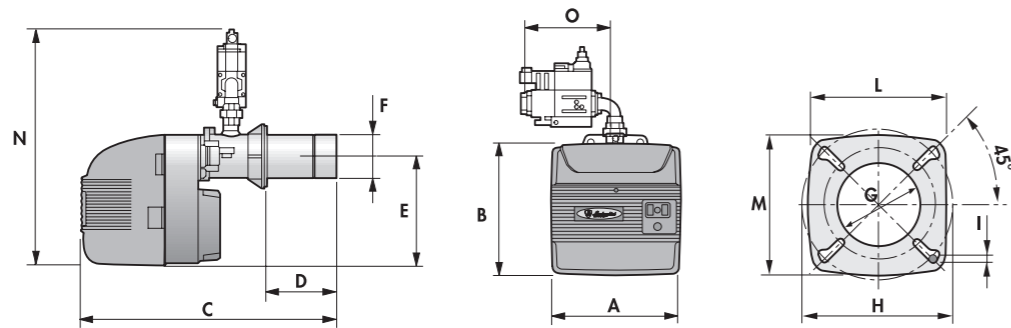

EM 40/M-E burner

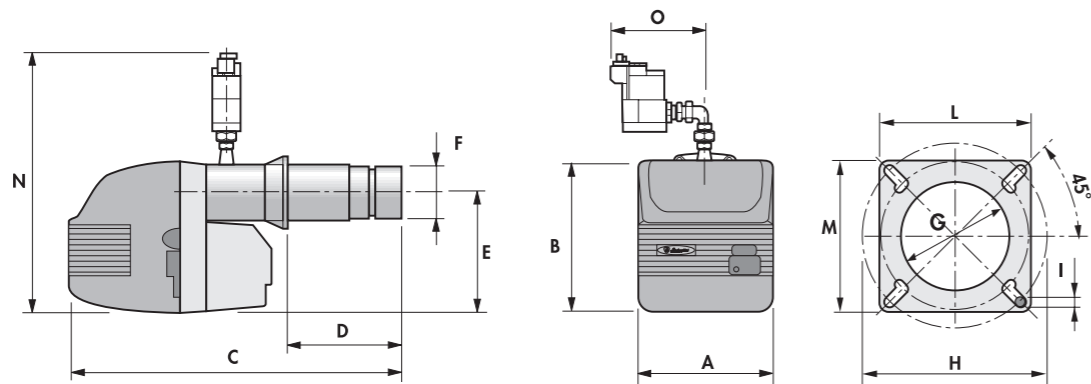

EM 50/M-E EM 70/M-E burners

	A	B	C	D		E	F	G	ØH		I	L	M	N*	O*
				mm.	mm.				mm.	mm.					
				min.	max.				min.	max.					
EM 26/M-E	360	350	750	100	265	275	140	155	172	225	M10	205	205	650	240
EM 40/M-E	420	423	880	120	310	350	140	155	172	225	M10	205	205	740	290
EM 50/M-E	420	420	1.070	200	400	392	170	180	225	283	M12	230	230	960	350
EM 70/M-E	420	490	1.110	200	400	392	170	180	225	283	M12	230	230	1.100	600

* Dimensions refer to the burner with a 20 mbar gas train installed. For other dimensions see the Lamborghini Burners Sales Technical Catalogue.

Technical data

EM			26/M-E	40/M-E	50/M-E	70/M-E
Delivery	min.	m ³ /h	13	16,3	14,6	21,1
	max	m ³ /h	25,1	39,2	58,5	74,4
Heat output	min.	kW	130	163	145	210
	max	kW	231	390	582	740
	min.	kcal/h	111.800	140.180	124.700	180.600
	max	kcal/h	215.000	335.400	500.520	636.400
Total absorbed power	W		490	1.050	1.700	2.100
Motor 2800 rpm	W		220	370	1.100	1.500
Power supply			230 V - 50 Hz		230/400 V - 50 Hz	
Gas category			II 2H 3+			

Pressure curves

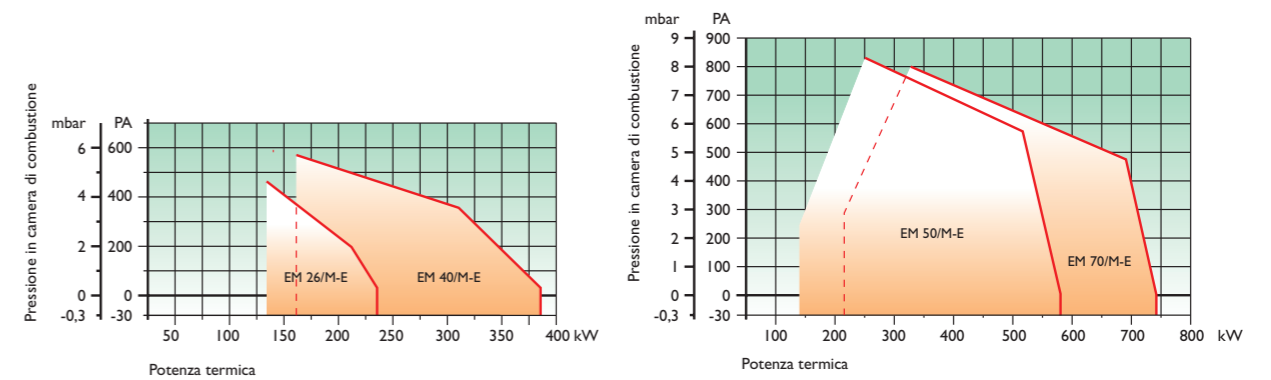

Burner-gas train matching

Models	Burner		Gas train				LPG kit
	Line connection	Heat Output kW	Size*	Min. pressure**		Max pressure***	
				Natural gas mbar	LPG. mbar		
EM 26/M-E.D7	1 1/4"	130 250	1 1/4"	15	-	360	NO
EM 26/M-E.D4	3/4"	130 250	3/4"	-	30	360	YES (see price list)
EM 26/M-E.D5	3/4"	130 250	3/4"	25	-	360	NO
EM 40/M-E.D7	1 1/4"	163 390	1 1/4"	18	-	360	NO
EM 40/M-E.D4	3/4"	163 390	3/4"	-	25	360	NO
EM 40/M-E.D5	3/4"	163 390	3/4"	45	-	360	NO
EM 50/M-E.D9	1 1/2"	145 582	1 1/2"	20	-	360	NO
EM 50/M-E.D7	1 1/4"	145 582	1 1/4"	-	17	360	YES (see price list)
EM 50/M-E.D8	1 1/4"	145 582	1 1/4"	25	-	360	NO
EM 70/M-E.D11	2"	210 740	2"	18	-	360	NO
EM 70/M-E.D7	1 1/4"	210 740	1 1/4"	-	24	360	YES (see price list)
EM 70/M-E.D8	1 1/4"	210 740	1 1/4"	30	-	360	NO

* For further information about burner and gas train matching see the Lamborghini Burners Sales Technical Catalogue.

** Minimum gas pressure to obtain burner maximum output.

*** Maximum operating pressure of gas valves.